

HUD-1 Plastic anchor

Economical universal plastic anchor

Anchor version



HUD-1
(d5-d14)

Benefits

- Flat setting
- Flexibility of screw length
- An anchor for every base material

Base material



Concrete
(non-cracked)

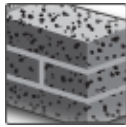

Solid brick

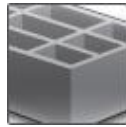

Hollow brick

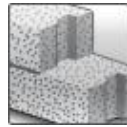

Autoclaved
aerated
concrete



Drywall

Basic loading data

All data in this section applies to:

- Correct setting (See setting instruction)
- Load data are only valid for the specified wood screw type
- No edge distance and spacing influence
- Base material as specified in the table
- Minimum base material thickness

Anchorage depth

Anchor size		5x25	6x30	8x40	10x50	12x60	14x70
Nominal anchorage depth	h_{nom} [mm]	25	30	40	50	60	70

Characteristic resistance

Anchor size		5x25		6x30		8x40		10x50		12x60	14x70
Screw type ^{d)}		W	C	W	C	W	C	W	C	W	W
Size		4	4	5	5	6	6	8	8	10	12
DIN		96		96		96		96		571	571
Concrete \geq C16/20	N_{Rk} [kN]	1,5	0,5	2,75	1,75	4,25	2,5	7	-	10	15
	V_{Rk} [kN]	2	-	4,5	-	6,25	-	11	-	15	28
Solid clay brick Mz 20	N_{Rk} [kN]	0,85	0,3	1,75	0,75	3	1,75	4	-	5	5 ^{c)}
	V_{Rk} [kN]	1,2	-	1,5	-	2,2	-	-	-	-	-
Solid sand-lime Brick KS 12	N_{Rk} [kN]	1,25	0,75	2,5	1,5	4,25	2	5	-	7,5	7,5 ^{c)}
	V_{Rk} [kN]	1,25	-	2,8	-	3,7	-	6,6	-	-	-
Hollow clay brick HlzB 12	N_{Rk} [kN]	0,4	0,25	0,5	0,4	1	0,6	1,25	-	1,4	1,6
	V_{Rk} [kN]	1,15	-	1,75	-	-	-	-	-	-	-
Hollow clay brick HlzB 12 – 15mm plastered	N_{Rk} [kN]	0,4	0,25	0,75	0,5	1,25	0,75	1,5	-	1,75	2
	V_{Rk} [kN]	1,15	-	1,75	-	-	-	-	-	-	-
Autoclaved aerated concrete AAC 2	N_{Rk} [kN]	0,3	0,2	0,5	0,3	0,75	0,5	1	-	1,25	1,5
	V_{Rk} [kN]	0,2	-	0,25	-	0,4	-	-	-	-	-
Autoclaved aerated concrete AAC 4	N_{Rk} [kN]	0,5	0,3	0,75	0,5	1,5	1	2	-	2,5	3
	V_{Rk} [kN]	0,65	-	0,9	-	1,5	-	-	-	-	-
Gypsum board Thickness 12,5mm	N_{Rk} [kN]	0,2	0,3	0,25	0,4	0,3	0,5	-	0,75 ^{a)}	-	-
	V_{Rk} [kN]	0,45	-	0,7	-	-	-	-	-	-	-
Gypsum board Thickness 2x12,5mm	N_{Rk} [kN]	0,3	0,3	0,4	0,4	0,5	0,5	0,75 ^{a)}	1 ^{a)}	1,5 ^{b)}	-
	V_{Rk} [kN]	0,45	-	0,7	-	-	-	-	-	-	-
Fibre reinforced gypsum board Thickness 12,5mm	N_{Rk} [kN]	0,45	-	0,6	-	0,9	-	-	-	-	-
	V_{Rk} [kN]	0,72	-	0,96	-	1,44	-	-	-	-	-
Fibre reinforced gypsum board Thickness 2x12,5mm	N_{Rk} [kN]	0,45	-	1,2	-	1,8	-	2,1	-	-	-
	V_{Rk} [kN]	0,72	-	1,92	-	2,88	-	3,36	-	-	-

a) only with screw diameter 6mm

b) only with screw diameter 8mm

c) only with screw diameter 10mm

d) Screw type: W: Wood-screw C: Chipboard screw

Load data are valid for the mentioned woodscrew type, if other types or different screws are used the load capacity may decrease.

Design resistance

Anchor size		5x25		6x30		8x40		10x50		12x60	14x70
Screw type ^{d)}		W	C	W	C	W	C	W	C	W	W
Size		4	4	5	5	6	6	8	8	10	12
DIN		96		96		96		96		571	571
Concrete ≥ C16/20	N _{Rd} [kN]	0,42	0,14	0,77	0,49	1,19	0,70	1,96	-	2,80	4,20
	V _{Rd} [kN]	0,56	-	1,26	-	1,75	-	3,08	-	4,20	7,84
Solid clay brick Mz 20	N _{Rd} [kN]	0,24	0,08	0,49	0,21	0,84	0,49	1,12	-	1,40	1,40 ^{c)}
	V _{Rd} [kN]	0,34	-	0,42	-	0,62	-	-	-	-	-
Solid sand-lime brick KS 12	N _{Rd} [kN]	0,35	0,21	0,70	0,42	1,19	0,56	1,40	-	2,10	2,10 ^{c)}
	V _{Rd} [kN]	0,35	-	0,78	-	1,04	-	1,85	-	-	-
Hollow clay brick HlzB 12	N _{Rd} [kN]	0,11	0,07	0,14	0,11	0,28	0,17	0,35	-	0,39	0,45
	V _{Rd} [kN]	0,32	-	0,49	-	-	-	-	-	-	-
Hollow clay brick HlzB 12 – 15mm plastered	N _{Rd} [kN]	0,11	0,07	0,21	0,14	0,35	0,21	0,42	-	0,49	0,56
	V _{Rd} [kN]	0,32	-	0,49	-	-	-	-	-	-	-
Autoclaved aerated concrete AAC 2	N _{Rd} [kN]	0,08	0,06	0,14	0,08	0,21	0,14	0,28	-	0,35	0,42
	V _{Rd} [kN]	0,06	-	0,07	-	0,11	-	-	-	-	-
Autoclaved aerated concrete AAC 4	N _{Rd} [kN]	0,14	0,08	0,21	0,14	0,42	0,28	0,56	-	0,70	0,84
	V _{Rd} [kN]	0,18	-	0,25	-	0,42	-	-	-	-	-
Gypsum board Thickness 12,5mm	N _{Rd} [kN]	0,06	0,08	0,07	0,11	0,08	0,14	-	0,21 ^{a)}	-	-
	V _{Rd} [kN]	0,13	-	0,20	-	-	-	-	-	-	-
Gypsum board Thickness 2x12,5mm	N _{Rd} [kN]	0,08	0,08	0,11	0,11	0,14	0,14	0,21 ^{a)}	0,28 ^{a)}	0,42 ^{b)}	
	V _{Rd} [kN]	0,13	-	0,20	-	-	-	-	-	-	-
Fibre reinforced gypsum board Thickness 12,5mm	N _{Rd} [kN]	0,13	-	0,17	-	0,25	-	-	-	-	-
	V _{Rd} [kN]	0,20	-	0,27	-	0,40	-	-	-	-	-
Fibre reinforced gypsum board Thickness 2x12,5mm	N _{Rd} [kN]	0,13	-	0,34	-	0,50	-	0,59	-	-	-
	V _{Rd} [kN]	0,20	-	0,54	-	0,81	-	0,94	-	-	-

a) only with screw diameter 6mm

b) only with screw diameter 8mm

c) only with screw diameter 10mm

d) Screw type: W: Wood-screw C: Chipboard screw

Load data are valid for the mentioned woodscrew type, if other types or different screws are used the load capacity may decrease.

Recommended loads^{e)}

Anchor size		5x25		6x30		8x40		10x50		12x60	14x70
Screw type ^{d)}		W	C	W	C	W	C	W	C	W	W
Size		4	4	5	5	6	6	8	8	10	12
DIN		96		96		96		96		571	571
Concrete ≥ C16/20	N _{Rec} [kN]	0,3	0,1	0,55	0,35	0,85	0,5	1,4	-	2	3
	V _{Rec} [kN]	0,4	-	0,9	-	1,25	-	2,2	-	3	5,6
Solid clay brick Mz 20	N _{Rec} [kN]	0,17	0,06	0,35	0,15	0,6	0,35	0,8	-	1	1 ^{c)}
	V _{Rec} [kN]	0,24	-	0,3	-	0,44	-	-	-	-	-
Solid sand-lime brick KS 12	N _{Rec} [kN]	0,25	0,15	0,5	0,3	0,85	0,4	1	-	1,5	1,5 ^{c)}
	V _{Rec} [kN]	0,25	-	0,56	-	0,74	-	1,32	-		
Hollow clay brick HlzB 12	N _{Rec} [kN]	0,08	0,05	0,1	0,08	0,2	0,12	0,25	-	0,28	0,32
	V _{Rec} [kN]	0,23	-	0,35	-	-	-	-	-	-	-
Hollow clay brick HlzB 12 – 15mm plastered	N _{Rec} [kN]	0,08	0,05	0,15	0,1	0,25	0,15	0,3	-	0,35	0,4
	V _{Rec} [kN]	0,23	-	0,35	-	-	-	-	-	-	-
Autoclaved aerated concrete AAC 2	N _{Rec} [kN]	0,06	0,04	0,1	0,06	0,15	0,1	0,2	-	0,25	0,3
	V _{Rec} [kN]	0,04	-	0,05		0,08			-		
Autoclaved aerated concrete AAC 4	N _{Rec} [kN]	0,1	0,06	0,15	0,1	0,3	0,2	0,4	-	0,5	0,6
	V _{Rec} [kN]	0,13	-	0,18	-	0,3	-	-	-	-	-
Gypsum board Thickness 12,5mm	N _{Rec} [kN]	0,04	0,06	0,05	0,08	0,06	0,1	-	0,15 ^{a)}	-	-
	V _{Rec} [kN]	0,09	-	0,14	-	-	-	-	-	-	-
Gypsum board Thickness 2x12,5mm	N _{Rec} [kN]	0,06	0,06	0,08	0,08	0,1	0,1	0,15 ^{a)}	0,2 ^{a)}	0,3 ^{b)}	-
	V _{Rec} [kN]	0,09	-	0,14	-	-	-	-	-	-	-
Fibre reinforced gypsum board Thickness 12,5mm	N _{Rec} [kN]	0,09	-	0,12	-	0,18	-	-	-	-	-
	V _{Rec} [kN]	0,14	-	0,19	-	0,29	-	-	-	-	-
Fibre reinforced gypsum board Thickness 2x12,5mm	N _{Rec} [kN]	0,09	-	0,24	-	0,36	-	0,42	-	-	-
	V _{Rec} [kN]	0,14	-	0,38	-	0,58	-	0,67	-	-	-

a) only with screw diameter 6mm

b) only with screw diameter 8mm

c) only with screw diameter 10mm

d) Screw type: W: Wood-screw C: Chipboard screw

Load data are valid for the mentioned woodscrew type, if other types or different screws are used the load capacity may decrease.

 e) With overall global safety factor $\gamma = 5$ to the characteristic loads and a partial safety factor of $\gamma = 1,4$ to the design values.

Materials

Material quality

Part	Material
Plastic sleeve	Polyamide 6

Setting information

Installation temperature

-10°C to +40°C

Service temperature range

Hilti HUD-1 universal anchor may be applied in the temperature range given below.

Temperature range	Base material temperature	Max. long term base material temperature	Max. short term base material temperature
Temperature range I	-40 °C to +80 °C	+50 °C	+80 °C

Max short term base material temperature

Short-term elevated base material temperatures are those that occur over brief intervals, e.g. as a result of diurnal cycling.

Max long term base material temperature

Long-term elevated base material temperatures are roughly constant over significant periods of time.

Setting details

Anchor size		5x25	6x30	8x40	10x50	12x60	14x70
Nominal diameter of drill bit	d_o [mm]	5	6	8	10	12	14
Cutting diameter of drill bit	$d_{cut} \leq$ [mm]	5,35	6,4	8,45	10,45	12,5	14,5
Depth of drill hole	$h_1 \geq$ [mm]	35	40	55	65	80	90
Nominal anchorage depth	h_{nom} [mm]	25	30	40	50	60	70
Anchor length	l [mm]	25	30	40	50	60	70
Max fixture thickness	t_{fix} [mm]	Depending on screw length					
Woodscrew diameter ^{a)}	d [mm]	3,5 - 4	4,5 - 5	5 - 6	7 - 8	8 - 10	10 - 12

a) The basic loading data are depending on the woodscrew diameters, if other types or different screws are used the load capacity may decrease. **Highlighted diameters** refer to basic loading data table, except footnotes ^{a), b), c)} of basic loading data tables.

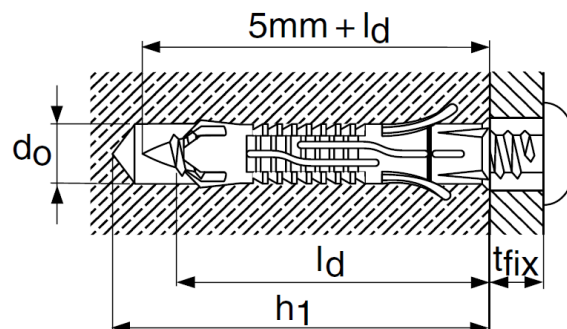

Installation equipment

Anchor size	5x25	6x30	8x40	10x50	12x60	14x70	5x25
Rotary hammer	TE 2 - TE16						
Other tools	Screwdriver						

Setting instruction^{a)}

***For detailed information on installation see instruction for use given with the package of the product.**

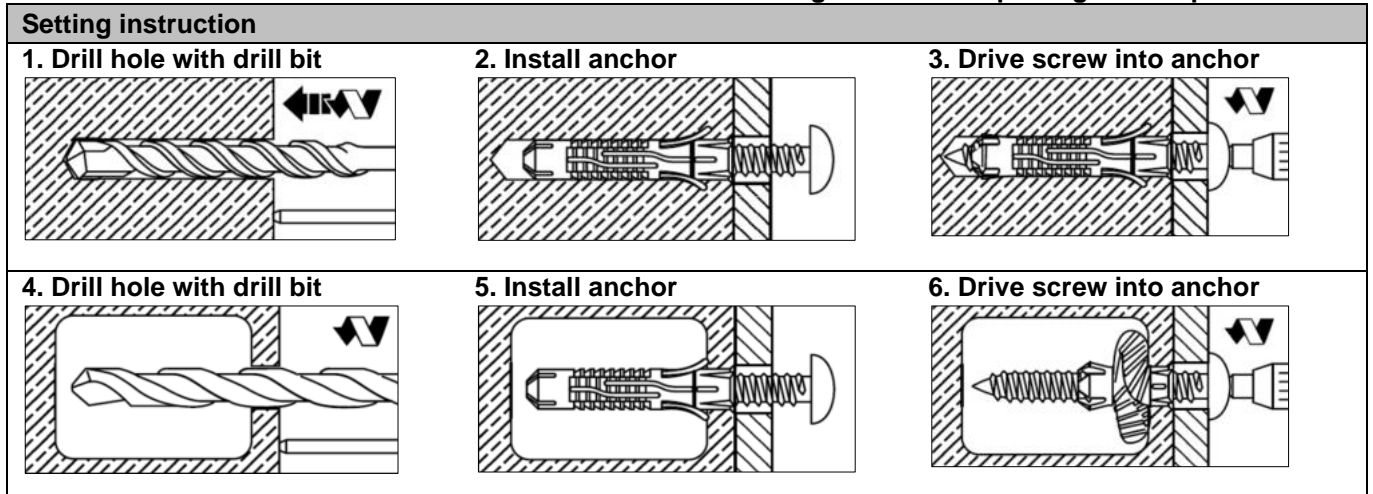

a) Use only for wall and floor applications. Not applicable for ceiling and façade applications.